

d:0;RL

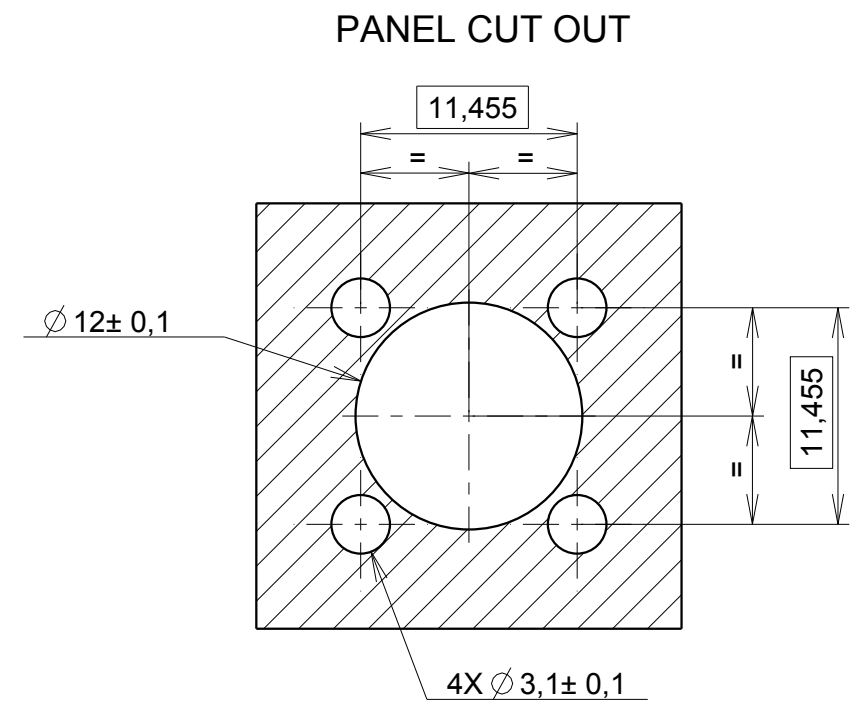

AVAILABLE LAYOUTS

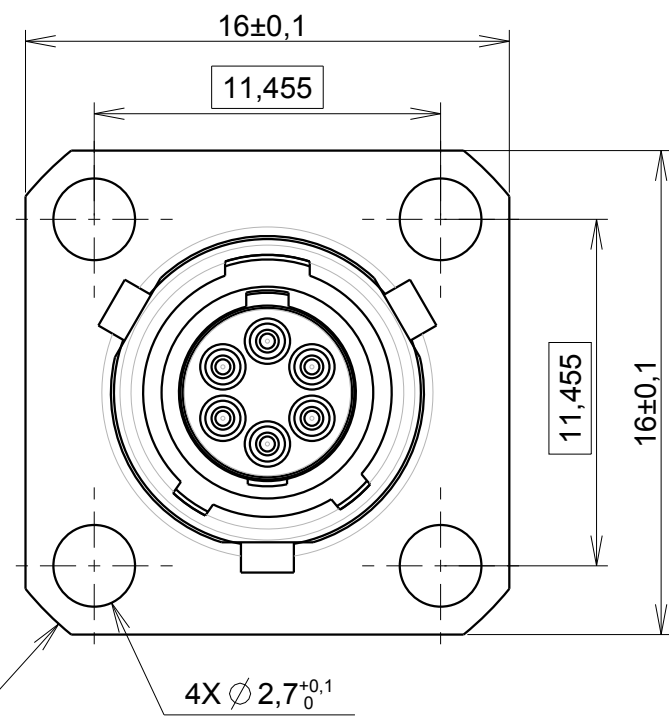
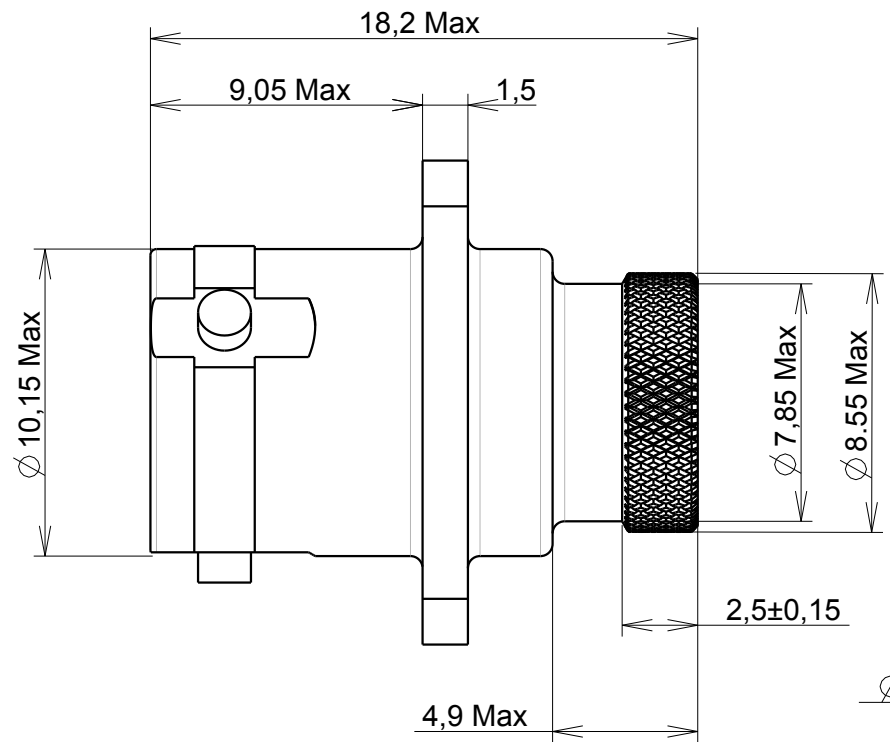
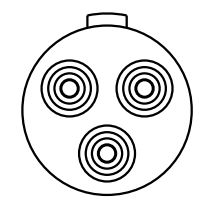

Layout 05-35
(3#22)

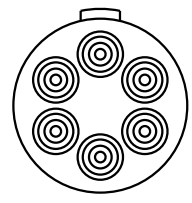

Layout 05-06
(6#26)

Position	α°	β°
N	145°	75°
A	130°	120°
B	110°	120°
C	155°	115°
D	90°	115°
E	90°	180°

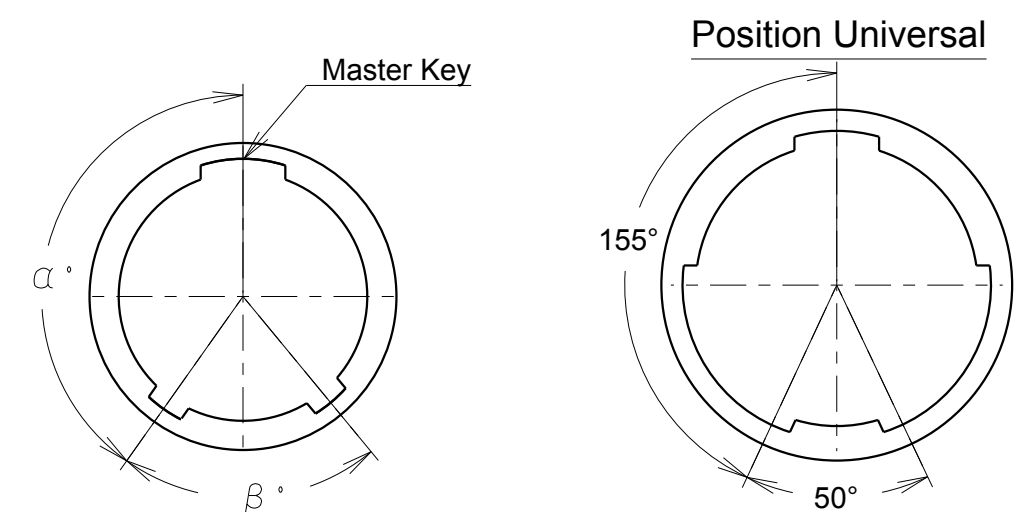

P/N : SEE TABLE

PART NUMBER : 8LTA0-05F06PN

- Square flange receptacle
- Connector with crimp contacts
- Shell size: 05

Orientation :
N-A-B-C-D-E-U

Contact type :
-P : Pin
-S : Socket

Contact layout :
05-06 (6 #26)
05-35 (3 #22)

- Plating :
- Z : Aluminium with Black Zinc Nickel
 - F : Aluminium with Nickel
 - W : Aluminium with Olive Green Cadmium
 - K : Passivated Stainless Steel

d	20/09/2011	Mise à jour et Diffusion pour dossier 8LTA INOX		21247 M
ISS	DATE	Latest modification - by:	PRIOUL. C	MOD N°
Designed by:		MILLE. C	Date: 26/06/10	CUSTOMER DRAWING
TITLE		SQUARE FLANGE RECEPTACLE 8LTA SERIE TYPE 0 - BOITIER 05		
Scale	3/1	NPRDS / PROJECT 8LTA		
		WWW.SOURIAU.COM		This document is the property of SOURIAU. It must not be reproduced or communicated without permission.
FORMAT	A3	SOURIAU DRG N° C002-8LTA-A		SHEET 1/1

NOT EXPORT CONTROLLED